

J&G COUGHTRIE

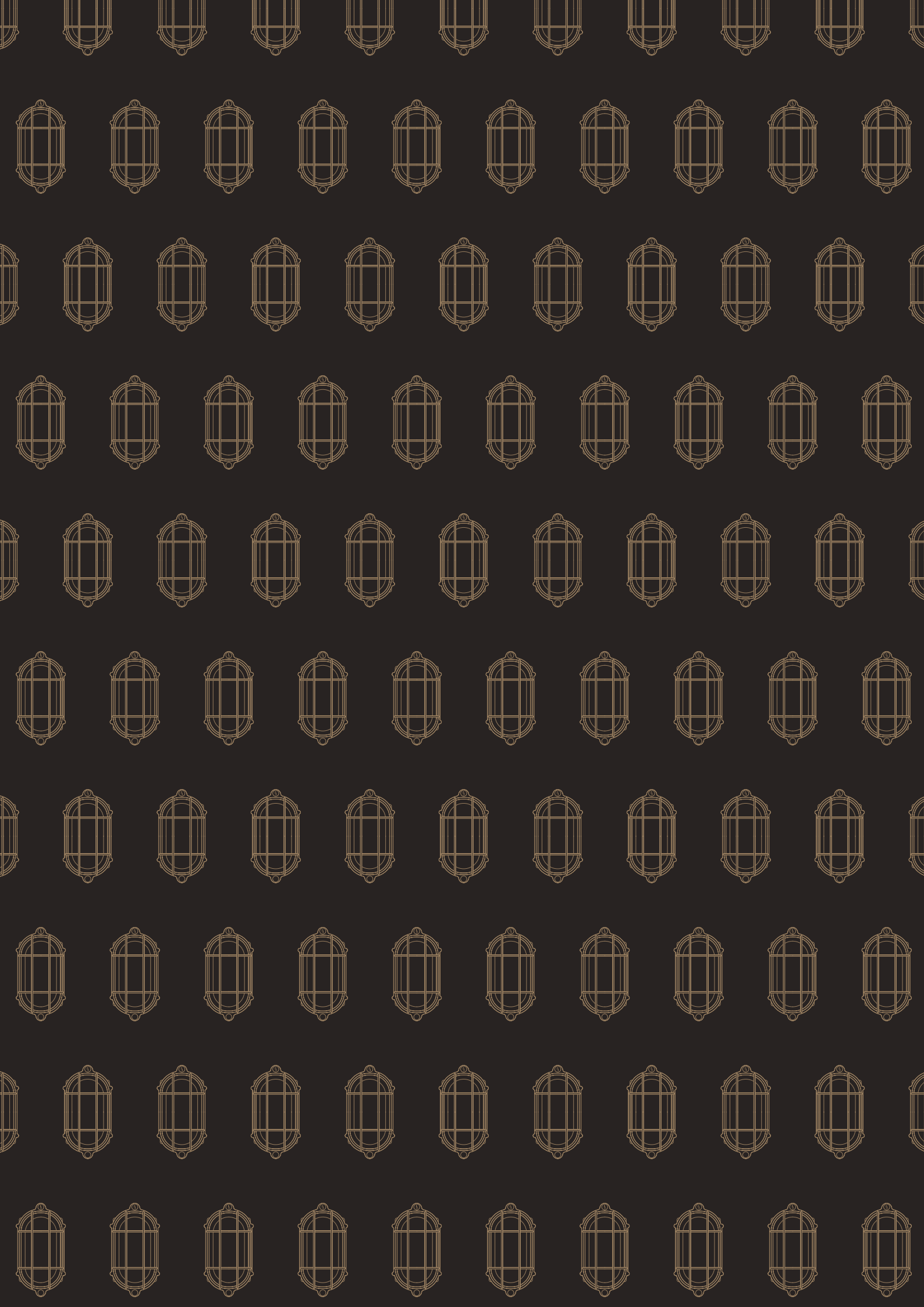

SP-12 LARGE OVAL LED BULKHEAD WITH CAGE



J&G COUGHTRIE

Trusted by our discerning customers for over eight decades, our UK-made industrial lighting features simple, geometric forms with enduring style and robust construction. Built to last a lifetime, our products are made from the finest quality materials, with the highest spec finishes - quite simply spiffing.



Made in Britain since 1939.

TRUSTED, TIMELESS & ENDURING.

Founded in 1939, by a pair of Glaswegian brothers, our original industrial lighting can still be found, working reliably, across the UK. Robust, and sustainably made, we're proud to continue a rich legacy in lighting, spanning over eight decades.

J&G Coughtrie lighting is expertly engineered in the UK, using the finest materials, and skillful craftsmanship. This helps our customers leave a sustainable legacy, with products reimagined, and redefined, for a modern audience, all while preserving traditional techniques, and values (the old adage, 'they don't make 'em like they used to, definitely doesn't apply to us).

Our lights are the product of over 80 years of experience, with manufacturing processes and craftsmanship refined through multiple generations, grounded in traditional handcrafting methods.

We work with our customers on a wide variety of ventures, from lighting schemes for conservation and restoration projects, to tailored light fittings for hotels, homes, offices, and hospitality venues - both inside, and out. We've also worked on a film, set or two, and know a thing or two about creating the right mood for any scene.

1. Recycled
Aluminium

2. Freshly cast
SY-6 Casing



1.



2.

Our light casings are cast from solid aluminium, with each piece hand finished to remove rough edges, before being powder coated to keep it looking pristine, for longer. Our local Mastercasters have been making Coughtrie casings for decades, some still using original tools from the 1940s and 1950s.

**“TRADITIONAL DESIGN, ENDURING CRAFTSMANSHIP.
COMBINING OVER 80 YEARS OF EXPERIENCE
PRODUCING TIMELESS INDUSTRIAL LIGHTING.”**

Our glass diffusers are custom designed, and moulded in thick, robust glass, diffusing the light evenly, and gently - regardless of the intensity of the bulb inside. Made with care, our glass translates love into light of the finest possible quality. Each of our lights is made to order, with an industry leading product time that sees us combine quality with speed - a rare feat in any industry.

Our lights are rigorously tested by our team before being shipped, many of whom have been with us for over 40 years, with invaluable experience honed over decades.

Quality guaranteed, our lighting range is built to last a lifetime, with each product made to order, individually hand-assembled, and quality checked at our factory in Glasgow. Enduring quality, our products are protected by up-gradable and replaceable technologies combined with rust protected casings to stand the test of time.

J&G Coughtrie has been following sustainable manufacturing and design practices for 80 years - because we believe that sustainable design is simply good design. Made within only recycled, and recyclable materials, our lights are designed for easy disassembly, using mechanical fixings that can be taken apart, repaired, and upgraded, rather than glue. Our suppliers are also locally based, helping to reduce our carbon footprint.

SP-12 LARGE OVAL LED BULKHEAD WITH CAGE

Indoor-Outdoor

First made in the 1950s, the Caged SP-12 Bulkhead has been recreated for discerning modern customers like you, and fitted with 12W LEDs for better energy efficiency, and a brighter, whiter, lighter output. Now coupled with a handmade steel cage, it's the ideal light for high pass-through environments prone to knocks especially when increased visibility is vital.



3. SP-12 Large Oval
LED Bulkhead with
Cage, White

3. SP-12 Large Oval
LED Bulkhead with
Cage, Black

3.



SP-12 LARGE OVAL LED BULKHEAD WITH CAGE

1

HOODED POWER PORTS

Rear, top and bottom access for power cable connection.

2

WINGED SCREW FLANGES

The external screw mounting points enable the SP-12 to be quickly fixed in place, without needing to go to the trouble of prising open the casing. Perfection!

3

GLASS WITH CLASS, CHAPS

Thick, hand pressed, and blown glass diffuser, with distinctive decorative ribs, and our iconic Coughtrie brand mark. Available in clear or opal glass.

4

SHAPED FOR SERVICE

The SP-12's imposing yet classic oval style provides beauty with a practical purpose, for long lasting style and functionality. Both salt spray certified, and section 12 tunnel approved - this is one rugged light!

5

HAND-FORMED CAGE

The robust, hand-formed steel cage is mounted securely to the winged screw flanges and features 2 laser etched J&G Coughtrie branding disks.

6

ULTRA EFFICIENT 12W LEDS

The 12W LEDs generate a bright, white, modern flood of light that provides extra clarity where required. They're also guaranteed for 50,000 hours, before they need to be replaced, easing your environmental woes.

5. SP-12 Large Oval LED Bulkhead with Cage, Industrial Aluminium



5.

FALL IN LOVE AT FIRST LIGHT

Brighter, whiter and lighter for the planet, see why the Caged SP-12 Large Oval LED Bulkhead is suited to the discerning modern customer.



6.

6. SP-12 Large Oval LED Bulkhead with Cage, White

7. SP-12 Large Oval LED Bulkhead with Cage, Gloss Grey

8. SP-12 Large Oval LED Bulkhead with Cage, Industrial Aluminium



7.

A Wall-To-Wall Mounting Winner

The marvellously versatile Caged SP-12 can be wall and ceiling mounted, both indoors, and outdoors, making it one of our most versatile lights. From bathrooms and stairwells to rail tunnels and cooker hoods, the world really is your oyster, old chap.



8.

The Ultimate Cage Lighter

Rated to IK10, the caged SP-12 shrugs off knocks without a second thought - Queensberry rules or not, my good man! The robust, hand-formed steel cage is mounted securely to the winged screw flanges and features 2 laser etched J&G Coughtrie branding disks. Each cage is treated to prevent rusting and painted to match the casing colour and can be purchased separately if desired.

PAINTENTLY PERFECT



Gloss Grey



Black



Antique Bronze

Colour

The Caged SP-12 can be finished with several different options, to suit your flights of fancy, from powder-coated paint in a range of colours, to an industrial aluminium finish which simply has a clear, protective lacquer applied to achieve that raw, manufactured industrial look, creating an unique and distinct finish each time.

With our bespoke finishing service, you'll also be able to specify a unique RAL colour, for powder coating.



White



Industrial Aluminium

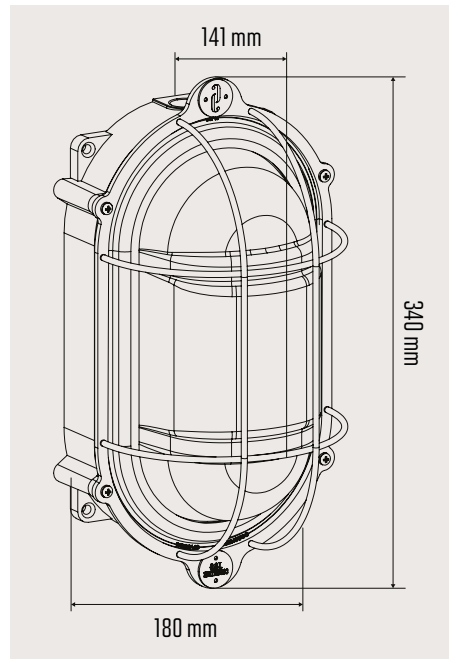

Any RAL Colour of Choice

Customise

Choose between Clear or Opal Glass Diffuser, and don't forget to include Presence Detection to optimise when your light is in use, or Emergency 3hr battery back-up for peace-of-mind in power cuts. The cage can also be purchased separately and fitted to existing SP-12 lights.

SP-12 LARGE OVAL LED BULKHEAD WITH CAGE

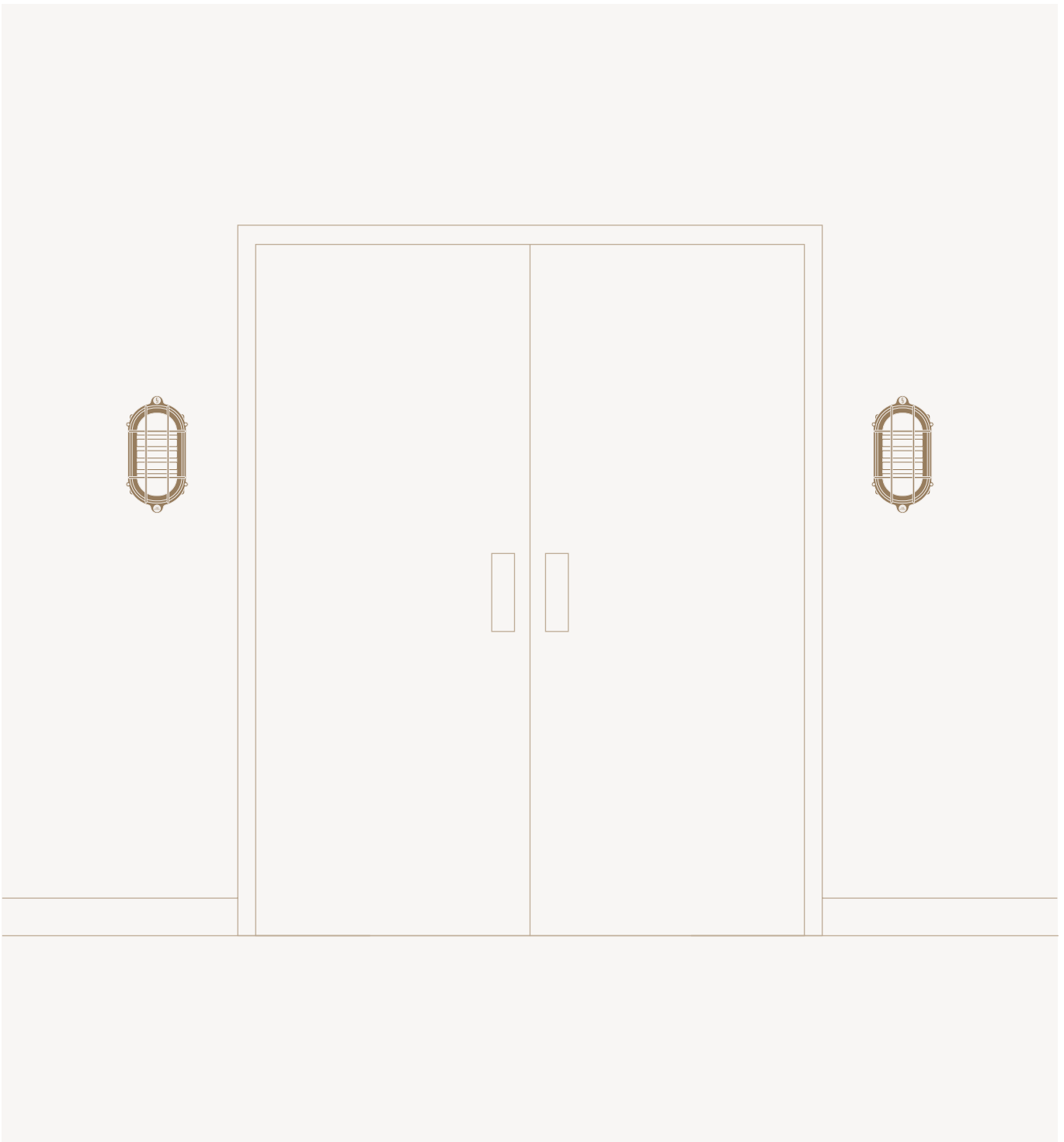

SAFETY & SECURITY

Ensure all essential entry and exits are well lit, with a pair of caged SP-12 Bulkheads, flanking the doorway.

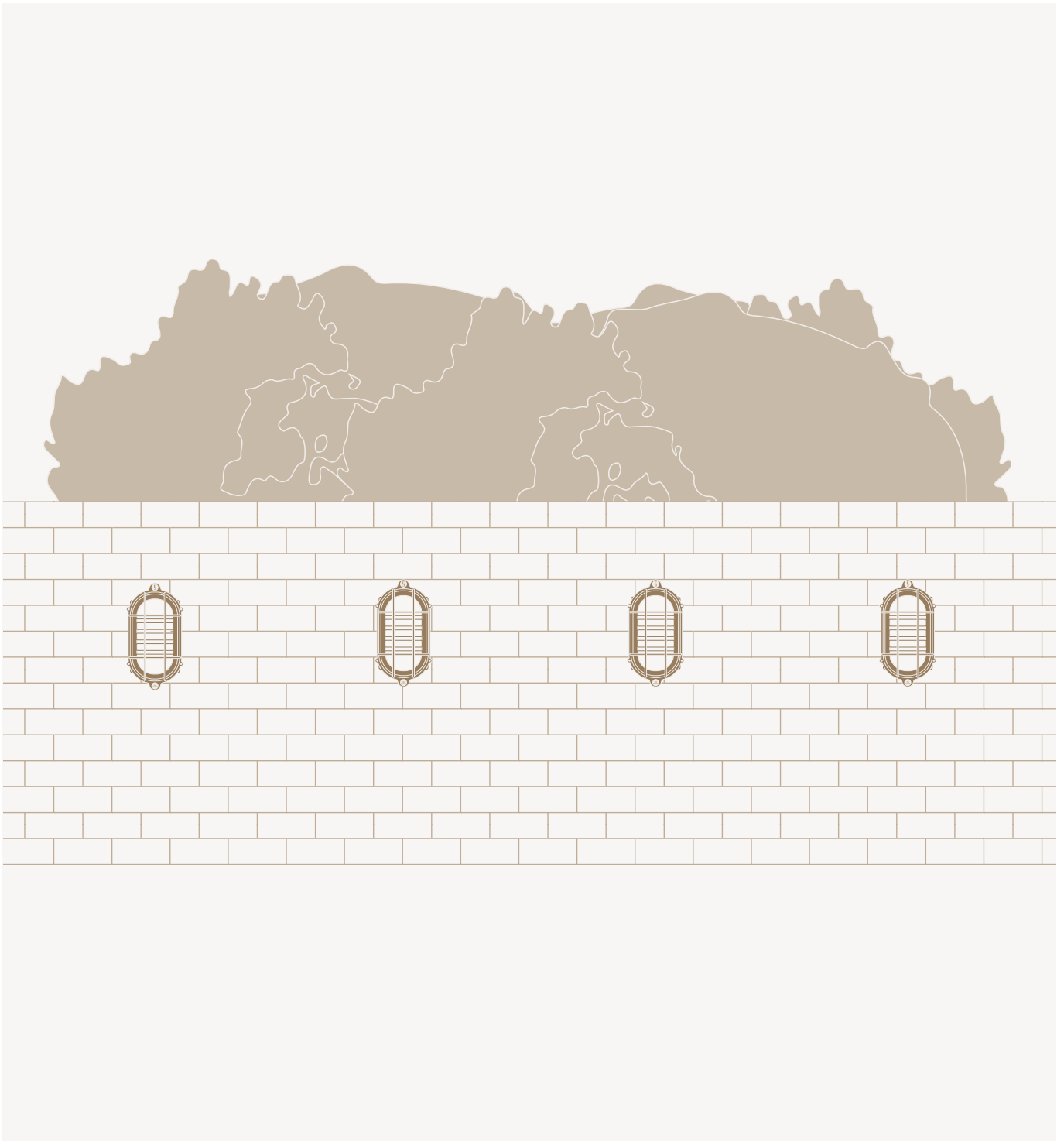

WONDER WALL

Definitely, maybe, the best way to reliably light your cark park or wall space with a line of SP-12 Bulkheads.

80 YEARS OF SUSTAINABILITY



BUILT TO LAST.

Our lights are tough cookies, built to last and suitable for even the most extreme applications (or even a Hollywood set!)



LOCAL SUPPLIERS.

We have a long-standing policy of using suppliers and manufacturing within a 40 miles radius, keeping it local is keeping it sustainable.



DESIGNED TO BE REPAIRED.

Our lights are designed to disassemble easily for repair or upgrade in the future as technology continues to improve.



SUSTAINABLE PACKAGING.

Each light is lovingly wrapped in recycled paper padding shipped in recycled cardboard packaging.

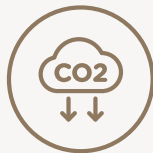

LOW CARBON MATERIALS.

Where possible, we make our parts from low carbon materials that are recycled or can be recycled at end of life.

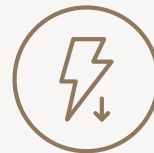

LOW ENERGY CONSUMPTION.

As lighting technology evolves, so do our lights. Now, we use low energy LED bulbs to minimise energy consumption.

PRODUCT INFORMATION

Weight	2500 grams
IP Rating	IP65: Suitable for inside or outside use in wet weather environments. IP rated as “dust tight” and protected against water projected from a nozzle.
Product Dimensions	Light fitting with cage: Length 340mm; Width 180mm; Depth: 141mm. Cage dimensions on its own: Length 340mm; Width 180mm; Depth: 90mm; Weight 300 grams.
Materials	Cast Aluminium Casing; Pressed And Blown Glass Diffuser; Sheet Aluminium Gear Tray; LED Board; Foam Gasket; Steel Screws; Powder Coated Paint / Aluminium Anodising Finishing, Stainless Steel Cage.

ELECTRICAL CHARACTERISTICS

Power	12W
Voltage	34.39V
Current	0.35A

LUMINAIRE CHARACTERISTICS

Bulb Type	LED
-----------	-----

**BE INSPIRED FOR YOUR NEXT PROJECT.
VISIT OUR SOCIAL MEDIA CHANNELS!**



@JG.COUGHTRIE

SP-12 LARGE OVAL LED BULKHEAD WITH CAGE

VARIATION	COLOUR	PRODUCT CODE
OPAL GLASS, STANDARD	Black	SP-12WLED/B/P+GUARD
	White	SP-12WLED/W/P+GUARD
	Antique Bronze	SP-12WLED/BRONZE/P+GUARD
	Industrial Aluminium	SP-12WLED/S/P+GUARD
	Gloss Grey	SP-12WLED/G/P+GUARD
OPAL GLASS, PRESENCE DETECTION	Black	SP-12WLED+MWD(MS.021)/B/P+GUARD
	White	SP-12WLED+MWD(MS.021)/W/P+GUARD
	Antique Bronze	SP-12WLED+MWD(MS.021)/BRONZE/P+GUARD
	Industrial Aluminium	SP-12WLED+MWD(MS.021)/S/P+GUARD
	Gloss Grey	SP-12WLED+MWD(MS.021)/G/P+GUARD
OPAL GLASS, BATTERY BACKUP	Black	SP-12WLED+EMG(LiFePO4)/B/P+GUARD
	White	SP-12WLED+EMG(LiFePO4)/W/P+GUARD
	Antique Bronze	SP-12WLED+EMG(LiFePO4)/BRONZE/P+GUARD
	Industrial Aluminium	SP-12WLED+EMG(LiFePO4)/S/P+GUARD
	Gloss Grey	SP-12WLED+EMG(LiFePO4)/G/P+GUARD
CLEAR GLASS, STANDARD	Black	SP-12WLED/B/CL+GUARD
	White	SP-12WLED/W/CL+GUARD
	Antique Bronze	SP-12WLED/BRONZE/CL+GUARD
	Industrial Aluminium	SP-12WLED/S/CL+GUARD
	Gloss Grey	SP-12WLED/G/CL+GUARD
CLEAR GLASS, PRESENCE DETECTION	Black	SP-12WLED+MWD(MS.021)/B/CL+GUARD
	White	SP-12WLED+MWD(MS.021)/W/CL+GUARD
	Antique Bronze	SP-12WLED+MWD(MS.021)/BRONZE/CL+GUARD
	Industrial Aluminium	SP-12WLED+MWD(MS.021)/S/CL+GUARD
	Gloss Grey	SP-12WLED+EMG(LiFePO4)/G/CL+GUARD
CLEAR GLASS, BATTERY BACKUP	Black	SP-12WLED+EMG(LiFePO4)/B/CL+GUARD
	White	SP-12WLED+EMG(LiFePO4)/W/CL+GUARD
	Antique Bronze	SP-12WLED+EMG(LiFePO4)/BRONZE/CL+GUARD
	Industrial Aluminium	SP-12WLED+EMG(LiFePO4)/S/CL+GUARD
	Gloss Grey	SP-12WLED+EMG(LiFePO4)/G/CL+GUARD
CAGE ON ITS OWN	Black	SP-GUARD/B
	White	SP-GUARD/W
	Antique Bronze	SP-GUARD/B
	Industrial Aluminium	SP-GUARD/S
	Gloss Grey	SP-GUARD/G



SP-12 Large Oval LED
Bulkhead with Cage,
Gloss Grey



+44 (0) 141 882 3262



J&G COUGHTRIE
69-71 MONTROSE AVENUE
HILLINGTON, GLASGOW, G52 4LA



sales@jgcoughtrie.com